

Overview

USFilter is a leading supplier of products and services to meet process and water treatment needs. Enterprise Automation's main focus with USFilter has been programming their ultrapure water systems. These systems typically consist of RO, DI and UV treatment systems. Enterprise Automation's experiences with USFilter have been very broad. They range from service call work (troubleshooting), all the way up to full electrical design, PLC programming and validation efforts.

Solution

Enterprise Automation has an extensive engineering background and USFilter has been able to take advantage this. Enterprise Automation also has engineers on staff with water/wastewater background which allows for terminology and communications to be streamlined. USFilter does not need to feel like they are talking to a programmer, but instead an engineer who understands the process. Enterprise Automation has worked with USFilter's project managers to help with the creation of a sequence of operations and with the manipulation of the P&IDs in order to optimize the sequence. Enterprise Automation has also taken on the roll of complete electrical design, and panel fabrication.

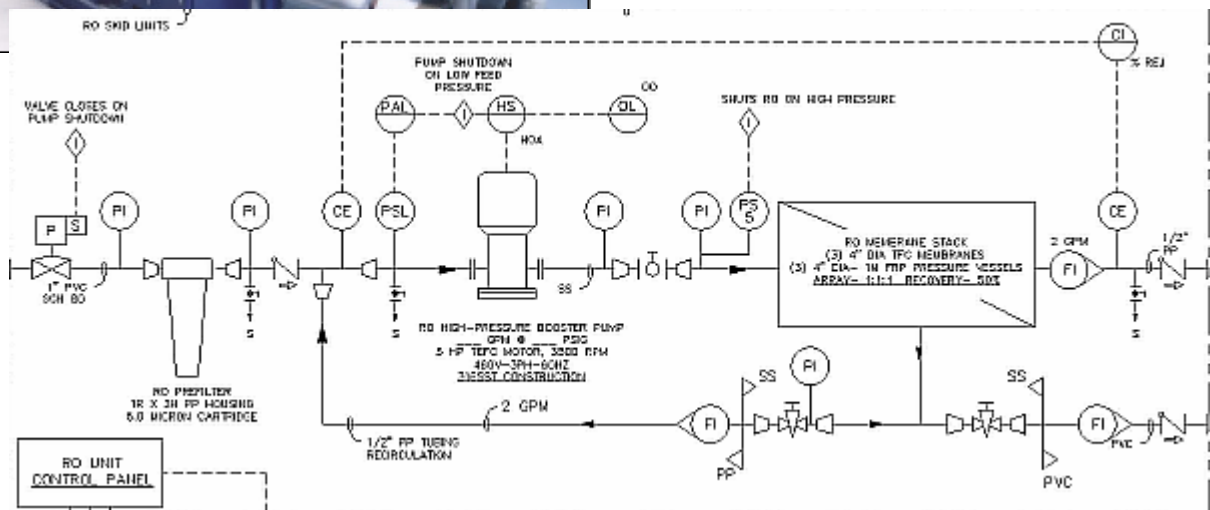

Technology

The typical system provided by USFilter will not include a SCADA system, but will typically require communications be made available for an existing SCADA or facility management system. All the USFilter projects have used Allen-Bradley PLCs, ranging from a simple Micrologix to SLC5/05 processors. Typically, tuning the water supply loop (with multiple high capacity drop points) is the most challenging task. However, Enterprise Automation has extensive experience with PID control making this task straightforward, and allowing for a high performance water supply loop.